

Low Carbon Steel  
& Grade 8

NYLON INSERT FLANGE STOP

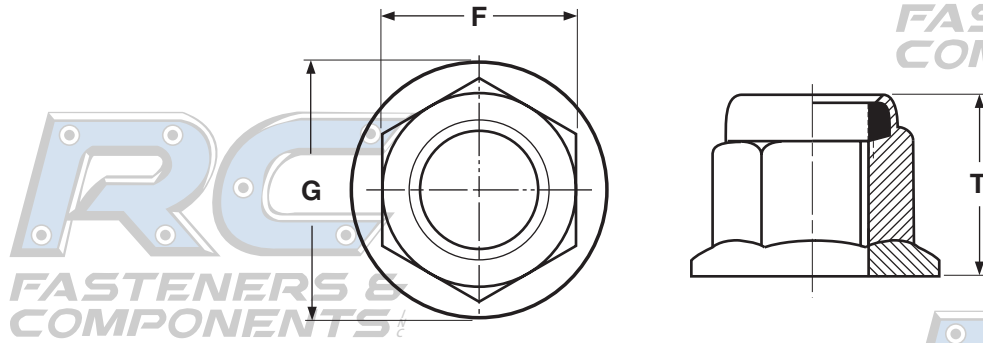

NYLON INSERT FLANGE LOCKNUTS

Size	B		G	T
	Width Across Flats		Flange Diameter	Thickness
	Max	Min	Max	Max
10-32	.375	.365	.500	.264
1/4-20	.438	.428	.560	.300
1/4-28	.438	.428	.560	.300
5/16-18	.500	.489	.680	.364
5/16-24	.500	.489	.680	.364
3/8-16	.562	.555	.810	.425
3/8-24	.562	.555	.810	.425
7/16-14	.688	.675	.930	.493
7/16-20	.688	.675	.930	.493
1/2-13	.750	.736	1.070	.554
1/2-20	.750	.736	1.070	.554
5/8-11	.938	.922	1.330	.690
5/8-18	.938	.922	1.330	.690
3/4-10	1.125	1.088	1.585	.825
3/4-16	1.125	1.088	1.585	.825

<b>Description</b>	Hex nut with a nylon-filled collar at its back end and an enlarged circular base flaring out from the front end of the nut. When an externally threaded fastener reaches the collar, the threads and nylon form a tight, frictional fit as the nylon applies downward pressure that forces contact between the internal and external threads.	
<b>Applications / Advantages</b>	The nut may be reused up to 50 times, does not damage the threads of the fastener it is used with, withstands extreme vibrations without loosening. The flange design allows the nut to span larger holes than a standard nylon insert stop nut while providing a more uniform bearing-stress to clamp-force ratio.	
<b>Material</b>	Low Carbon Steel	Grade-8
	AISI 1008 - 1035 steel	AISI C 1137 or equivalent steel
<b>Proof Load</b>	90,000 psi.	150,000 psi.
<b>Hardness</b>	Rockwell C 28 maximum	Rockwell C 26 - 34
<b>Plating</b>	Standard finish is clear zinc.	Standard finish is yellow zinc.