

Machine Screws Head Dimensions

Round Phillips Binding

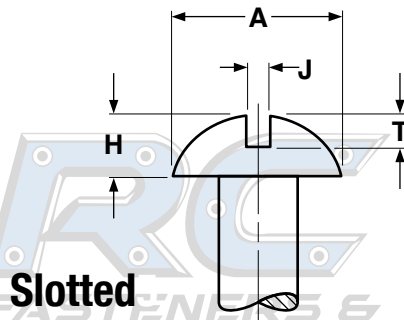

Slotted

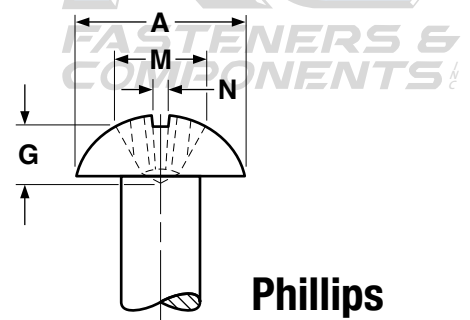

Phillips

ROUND HEADS FOR MACHINE SCREWS

ASME B18.6.3
2002

Nominal Size	A		H		J		T		M		G	N	Phillips Driver Size
	Head Diameter		Height of Head		Width of Slot		Depth of Slot		Dimensions of Recess				
	Max	Min	Max	Min	Max	Min	Max	Min	Max	Min	Max	Min	
2	.162	.146	.069	.059	.031	.023	.048	.037	.100	.087	.053	.017	1
3	.187	.169	.078	.067	.035	.027	.053	.040	.109	.096	.062	.018	1
4	.211	.193	.086	.075	.039	.031	.058	.044	.118	.105	.072	.019	1
5	.236	.217	.095	.083	.043	.035	.063	.047	.154	.141	.074	.027	2
6	.260	.240	.103	.091	.048	.039	.068	.051	.162	.149	.084	.027	2
8	.309	.287	.120	.107	.054	.045	.077	.058	.178	.165	.101	.030	2
10	.359	.334	.137	.123	.060	.050	.087	.065	.195	.182	.119	.031	2
12	.408	.382	.153	.139	.067	.056	.096	.073	.249	.236	.125	.032	3
1/4	.472	.443	.175	.160	.075	.064	.109	.082	.268	.255	.147	.034	3
5/16	.590	.557	.216	.198	.084	.072	.132	.099	.308	.295	.187	.040	3
3/8	.708	.670	.256	.237	.094	.081	.155	.117	.387	.374	.228	.064	4
1/2	.813	.766	.355	.332	.106	.091	.211	.159	.416	.403	.256	.068	4

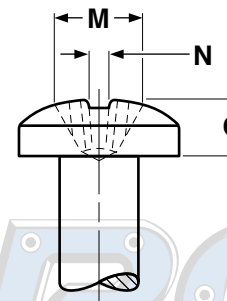
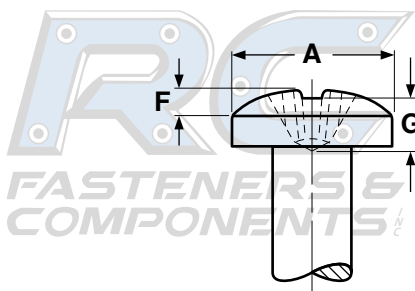

PHILLIPS BINDING HEADS FOR MACHINE SCREWS

ASME B18.6.3-2002

Nominal Size	A		O		F		M		G		N	Phillips Driver Size
	Head Diameter		Total Head Height		Head Oval Height		Recess Diameter		Recess Depth		Recess Width	
	Max	Min	Max	Min	Max	Min	Max	Min	Max	Min	Min	
2	.181	.171	.050	.043	.018	.013	.100	.087	.058	.041	.017	1
4	.235	.223	.068	.061	.025	.018	.118	.105	.077	.059	.017	1
6	.290	.275	.087	.078	.032	.024	.160	.147	.088	.064	.026	2
8	.344	.326	.105	.095	.039	.029	.186	.173	.114	.090	.028	2
10	.399	.378	.123	.112	.045	.034	.205	.192	.134	.109	.029	2
1/4	.525	.498	.165	.152	.061	.046	.281	.268	.164	.140	.046	3