

# HEAD DIMENSIONS Pan, 100° Flat

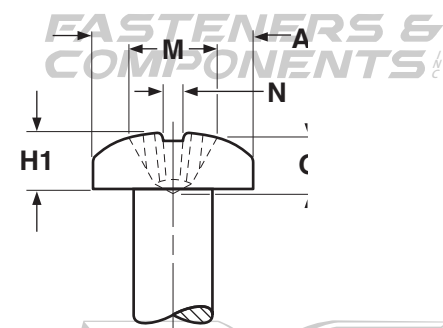

PAN HEADS FOR SELF-TAPPING AND DRILLING SCREWS															ASME B18.6.3-2013	
Nominal Size	A		H		H1		J		T		M			G	N	Phillips Driver Size
	Head Diameter		Height of Head				Width of Slot		Depth of Slot		Dimensions of Recess			Phillips Driver Size		
			Slotted		Recessed						Diameter		Depth		Width	
	Max	Min	Max	Min	Max	Min	Max	Min	Max	Min	Max	Min	Max		Min	
2	.167	.155	.053	.045	.062	.053	.031	.023	.031	.022	.104	.091	.059	.017	1	
3	.193	.180	.060	.051	.071	.062	.035	.027	.036	.026	.112	.099	.068	.019	1	
4	.219	.205	.068	.058	.080	.070	.039	.031	.040	.030	.122	.109	.078	.019	1	
5	.245	.231	.075	.065	.089	.079	.043	.035	.045	.034	.158	.145	.083	.028	2	
6	.270	.256	.082	.072	.097	.087	.048	.039	.050	.037	.166	.153	.091	.028	2	
7	.296	.281	.089	.079	.106	.096	.048	.039	.054	.041	.176	.163	.100	.029	2	
8	.322	.306	.096	.085	.115	.105	.054	.045	.058	.045	.182	.169	.108	.030	2	
10	.373	.357	.110	.099	.133	.122	.060	.050	.068	.053	.199	.186	.124	.031	2	
12	.425	.407	.125	.112	.151	.139	.067	.056	.077	.061	.259	.246	.141	.034	3	
14	.476	.457	.139	.126	.169	.156	.075	.064	.085	.068	.281	.268	.148	.036	3	
1/4	.492	.473	.144	.130	.175	.162	.075	.064	.087	.070	.281	.268	.161	.036	3	
5/16	.615	.594	.178	.162	.218	.203	.084	.072	.106	.085	.350	.337	.193	.059	4	
3/8	.740	.716	.212	.195	.261	.244	.094	.081	.124	.100	.389	.376	.233	.065	4	

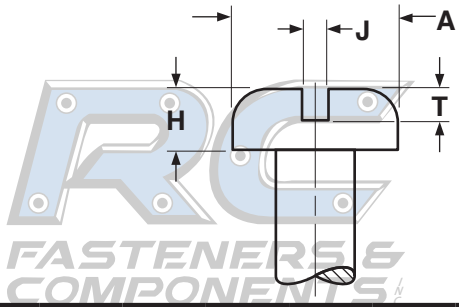
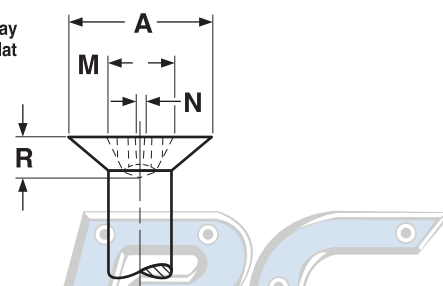
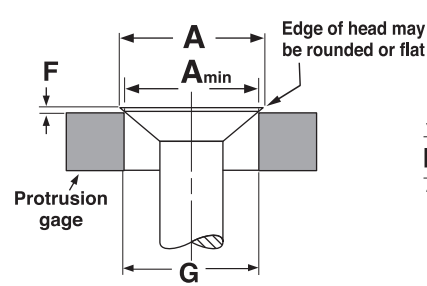
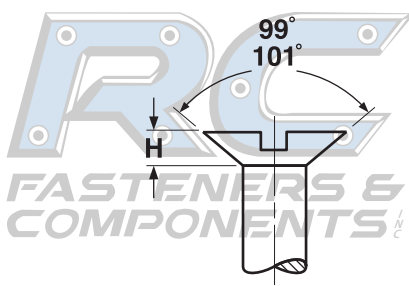

FLAT HEAD 100° FOR SELF-TAPPING SCREWS															ASME B18.6.3-2013
Nominal Size	A		H		J		T		M	R	N	F		G	Phillips Driver Size
	Head Dimensions				Slot Dimensions				Recess Dimensions			Protrusion Above Gaging Diameter		Gaging Diameter	
	Diameter		Height		Width		Depth		Diam.	Depth	Width	Max	Min		
	Max	Min	Max	Min	Max	Min	Max	Min	Ref	Ref	Ref	Max	Min		
4	.212	.188	.049	.039	.039	.031	.024	.017	.110	.070	.018	.025	.016	.167	1
6	.262	.235	.060	.049	.048	.039	.030	.022	.148	.074	.027	.028	.017	.214	2
8	.312	.282	.072	.060	.054	.045	.036	.027	.162	.090	.028	.031	.019	.261	2
10	.362	.329	.083	.070	.060	.050	.042	.031	.178	.104	.030	.034	.021	.307	2
1/4	.477	.437	.110	.094	.075	.064	.055	.042	.240	.124	.033	.040	.025	.415	3