

CENTER HOLE - WITHOUT PROJECTIONS

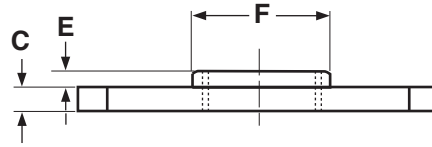
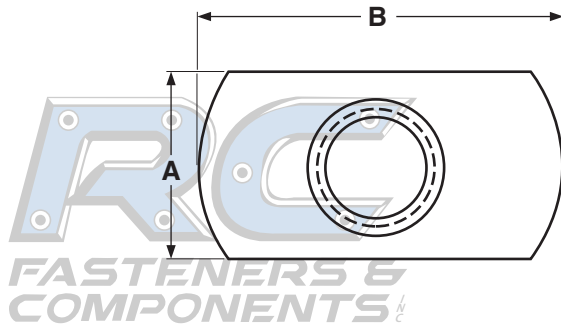

WELD NUTS, CENTER HOLE DESIGN WITHOUT PROJECTIONS

Paulin®

Size	A	C	B	F	E	Pilot Hole
	Width	Thickness	Length	Pilot Diameter	Pilot Height	
6-32	.453	.098	.890	.198	.042	.203
	.433	.088	.860	.178	.026	
8-32	.453	.098	.890	.213	.042	.219
	.433	.088	.860	.193	.026	
10-24	.453	.098	.890	.244	.042	.250
	.433	.088	.860	.224	.026	
10-32	.453	.098	.890	.244	.042	.250
	.433	.088	.860	.224	.026	
1/4-20	.453	.098	1.015	.307	.042	.312
	.433	.088	.985	.272	.026	
1/4-20	.520	.130	1.140	.307	.062	.312
	.495	.120	1.110	.287	.046	
5/16-18	.655	.145	1.515	.369	.092	.375
	.620	.135	1.485	.349	.075	
3/8-16	.655	.145	1.515	.448	.092	.453
	.620	.135	1.485	.428	.075	
1/2-13	.827	.192	1.515	.599	.102	.609
	.797	.178	1.485	.569	.085	

Description	A four-sided, internally threaded fastener with rounded edges at the two ends most opposite each other. The threaded hole runs through the center and has a pilot for the entire circumference of the opening which extends above the flat surface of the nut. The remaining top surface of the nut is flat.
Applications/ Advantages	The center hole design enables this nut to bridge corners or depressions offering additional strength. The tabs allow the installer to use multiple sizes of electrodes, thus improving efficiency by reducing equipment changes. The height of the pilot minimizes the amount of welding residue that could log the threads.
Material	1006 - 1010 Low Carbon Steel