

OFFSET HOLE - WITHOUT PROJECTIONS

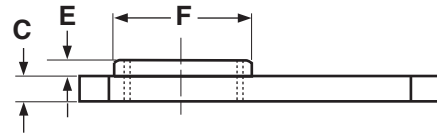

TAB WELD NUTS, OFFSET HOLE WITHOUT PROJECTIONS							Paulin®
Size	A Width	C Thickness	B Length	F Pilot Diameter	E Pilot Height	K Center of Pilot Hole to Outside of Rounded Edge	Pilot Hole
6-32	.453 .433	.097 .091	.640 .610	.198 .178	.042 .025	.202 .172	.203
8-32	.453 .433	.098 .088	.640 .610	.213 .193	.042 .025	.202 .172	.219
10-24	.453 .433	.098 .088	.640 .610	.244 .224	.042 .025	.201 .172	.250
10-32	.453 .433	.098 .088	.640 .610	.244 .224	.042 .025	.202 .172	.250
1/4-20	.448 .428	.097 .091	.953 .923	.307 .271	.047 .030	.270 .230	.312
1/4-20	.520 .495	.128 .122	.827 .797	.307 .287	.062 .045	.265 .235	.312
5/16-18	.448 .428	.128 .122	1.140 1.110	.369 .349	.092 .075	.301 .261	.375
3/8-16	.572 .552	.128 .122	1.265 1.235	.448 .428	.102 .085	.364 .324	.453
3/8-24	.572 .552	.128 .122	1.265 1.235	.448 .428	.102 .085	.364 .324	.453

FASTENERS & COMPONENTS

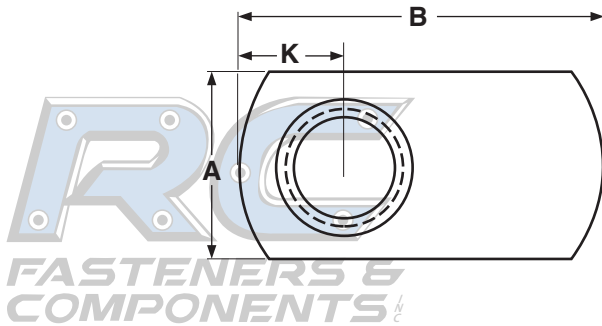

Description	A four-sided, internally threaded fastener with rounded edges at the two ends most opposite each other. The threaded hole runs through the center and has a pilot for the entire circumference of the opening which extends above the flat surface of the nut. The remainder of the top surface of the nut is flat.
Applications/ Advantages	This style weld nut is to be used with thinner gage metals to reinforce an area. The tab allows the installer to use multiple sizes of electrodes, thus improving efficiency by reducing equipment changes. The height of the pilot minimizes the amount of welding residue that could clog the threads.
Material	1006 - 1010 Low Carbon Steel

Paulin® is a registered trademark of Paulin Industries, Inc.